

## DESIGNING, MODELLING AND OPTIMISING OF AN INTEGRATED RELIABILITY REDUNDANT SYSTEM

G. Sankaraiah<sup>1</sup>, B.D. Sarma<sup>2</sup>, C. Umasankar<sup>3</sup> & V.S.S. Yadavalli<sup>4</sup>

<sup>1</sup>Mechanical Engineering Department  
G. Pulla Reddy Engineering College, Kurnool, A.P., India  
sankargandla74@yahoo.co.in

<sup>2</sup>Mechanical Engineering Department  
Narayana Engineering College, Nellore, A.P., India  
bdsarma@rediffmail.com

<sup>3</sup>Reliability and Statistical Quality Control Department  
Rayalaseema University, Kurnool, A.P., India  
cumaor@rediffmail.com

<sup>4</sup>Department of Industrial and Systems Engineering  
University of Pretoria, South Africa  
sarma.yadavalli@up.ac.za

(Dedicated to Prof K. Adendorff on his 80<sup>th</sup> birthday)

### ABSTRACT

The reliability of a system is generally treated as a function of cost; but in many real-life situations reliability will depend on a variety of factors. It is therefore interesting to probe the hidden impact of constraints apart from cost - such as weight, volume, and space. This paper attempts to study the impact of multiple constraints on system reliability. For the purposes of analysis, an integrated redundant reliability system is considered, modelled and solved by applying a Lagrangian multiplier that gives a real valued solution for the number of components, for its reliability at each stage, and for the system. The problem is further studied by using a heuristic algorithm and an integer programming method, and is validated by sensitivity analysis to present an integer solution.

### OPSOMMING

Die betroubaarheid van 'n sisteem word normaalweg as 'n funksie van koste beskou, alhoewel dit in baie gevalle afhang van 'n verskeidenheid faktore. Dit is dus interessant om die verskuilde impak van randvoorwaardes soos massa, volume en ruimte te ondersoek. Hierdie artikel poog om die impak van meervoudige randvoorwaardes op sisteem-betroubaarheid te bestudeer. Vir die ontleding, word 'n geïntegreerde betroubaarheid-sisteem met oortolligheid beskou, gemodelleer en opgelos aan die hand van 'n Lagrange-vermenigvuldiger. Die probleem word verder bestudeer deur gebruik te maak van 'n heuristiese algoritme en heeltalprogrammering asook gevalideer by wyse van 'n sensitiviteitsanalise sodat 'n heeltaloplossing voorgehou kan word.

## 1. INTRODUCTION

The reliability of a system can be increased by keeping redundant units, or by using components of greater reliability, or by employing both methods simultaneously [3,4]. Either of them consumes additional resources. Optimising system reliability, subject to resource availability such as cost, weight, and volume, is considered. Generally, reliability is treated as a function of cost; but when applied to real-life problems, the hidden impact of other constraints like weight, volume, etc, will have a definite impact on optimising reliability. The novel application of a redundant reliability model with multiple constraints is considered to optimise the proposed system.

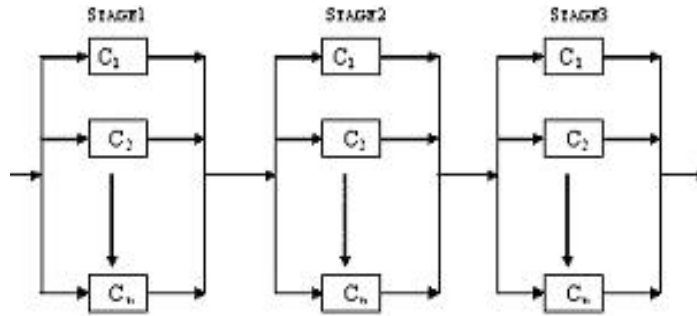

Figure 1: Series-parallel system

The problem considers the unknowns - that is, the number of components ( $x_j$ ), the component reliabilities ( $r_j$ ), and the stage reliability ( $R_j$ ) at each stage for a given multiple of constraints to maximise the system's reliability, which is called an integrated reliability model (IRM) [9]. In the literature, integrated reliability models are optimised using cost constraints where there is an established relation between cost and reliability. The novelty of the proposed work is its consideration of weight and volume as additional constraints, along with cost, to design and optimise the redundant reliability system for a series-parallel system configuration.

## 2. ASSUMPTIONS AND NOTATION

- All the components in each stage are assumed to be identical - i.e., all the components have the same reliability.
- The components are assumed to be statistically independent - i.e., the failure of a component does not affect the performance of other components in any system.

$R_s$  = System reliability

$R_j$  = Reliability of stage  $j$ ,  $0 < R_j < 1$

$r_j$  = Reliability of each component in stage  $j$ ,  $0 < r_j < 1$

$x_j$  = Number of components in stage  $j$

$c_j$  = Cost coefficient of each component in stage  $j$

$w_j$  = Weight coefficient of each component in stage  $j$

$v_j$  = Volume coefficient of each component in stage  $j$

$C_o$  = Maximum allowable system cost

$W_o$  = Maximum allowable system weight

$V_o$  = Maximum allowable system volume

$a_j$  = Constant

$b_j$  = Constant

- $p_j = \text{Constant}$
- $q_j = \text{Constant}$
- $u_j = \text{Constant}$
- $v_j = \text{Constant}$

### 3. MATHEMATICAL MODEL

The objective function and the constraints of the model

$$\text{Maximize } R_s = \prod_{j=1}^n [1 - (1 - r_j)^{x_j}] \tag{1}$$

subject to the constraints

$$\sum_{j=1}^n c_j \cdot x_j \leq C_0 \tag{2}$$

$$\sum_{j=1}^n w_j \cdot x_j \leq W_0 \tag{3}$$

$$\sum_{j=1}^n v_j \cdot x_j \leq V_0 \tag{4}$$

non-negative restriction that  $x_j$  is an integer and  $r_j, R_j > 0$

### 4. MATHEMATICAL FUNCTION

To establish the mathematical model, the most commonly-used function is considered for the purpose of reliability design and analysis. The proposed mathematical function

$$c_j = a_j \cdot \exp \left( \frac{b_j}{(1 - r_j)} \right) \tag{5}$$

where  $a_j, b_j$  are constants

System reliability for the given function

$$R_s = \prod_{i=1}^n R_j \tag{6}$$

The number of components at each stage  $X_j$  is given through the relation

$$x_j = \frac{\ln(1 - R_j)}{\ln(1 - r_j)} \tag{7}$$

The problem under consideration is

$$\text{Maximize } R_s = \prod_{j=1}^n [1 - (1 - r_j)^{x_j}] \tag{8}$$

subject to the constraints

$$\sum_{j=1}^n a_j \cdot \exp \left[ \frac{b_j}{(1-r_j)} \cdot \frac{\ln(1-R_j)}{\ln(1-r_j)} \right] \cdot C_0 \leq 0 \tag{9}$$

$$\sum_{j=1}^n p_j \cdot \exp \left[ \frac{q_j}{(1-r_j)} \cdot \frac{\ln(1-R_j)}{\ln(1-r_j)} \right] \cdot W_0 \leq 0 \tag{10}$$

$$\sum_{j=1}^n u_j \cdot \exp \left[ \frac{v_j}{(1-r_j)} \cdot \frac{\ln(1-R_j)}{\ln(1-r_j)} \right] \cdot V_0 \leq 0 \tag{11}$$

**5. THE LAGRANGIAN METHOD**

Solving the proposed formulation using the Lagrangian method:

$$F = R_s + \lambda_1 \left[ \sum_{j=1}^n \left[ a_j \cdot \exp \left[ \frac{b_j}{(1-r_j)} \cdot \frac{\ln(1-R_j)}{\ln(1-r_j)} \right] \cdot C_0 \right] + \lambda_2 \left[ \sum_{j=1}^n \left[ p_j \cdot \exp \left[ \frac{q_j}{(1-r_j)} \cdot \frac{\ln(1-R_j)}{\ln(1-r_j)} \right] \cdot W_0 \right] + \lambda_3 \left[ \sum_{j=1}^n \left[ u_j \cdot \exp \left[ \frac{v_j}{(1-r_j)} \cdot \frac{\ln(1-R_j)}{\ln(1-r_j)} \right] \cdot V_0 \right] \right] = 0 \tag{12}$$

where  $\lambda_1, \lambda_2, \lambda_3$  are Lagrangian multipliers.

The number of components in each stage ( $x_j$ ), the optimum component reliability ( $r_j$ ), the stage reliability ( $R_j$ ), and the system reliability ( $R_s$ ) are derived by using the Lagrangian method. The method provides a real valued solution with reference to cost, weight, and volume.

*i) Reliability design relating to cost*

Stage	$r_j$	$R_j$	$x_j$	$c_j$	$c_j \cdot x_j$
01	0.4697	0.8626	3.2	374	1197
02	0.4481	0.9205	4.3	512	2201
03	0.6000	0.9900	5.1	314	1602
Total cost					5000

Table 1: Cost constraint details

*ii) Reliability design relating to weight*

Stage	$r_j$	$R_j$	$x_j$	$W_j$	$W_j \cdot x_j$
01	0.4697	0.8626	3.2	548	1755
02	0.4481	0.9205	4.3	641	2757
03	0.6000	0.9900	5.1	576	2938
Total weight					7450

Table 2: Weight constraint details

iii) Reliability design relating to volume

Stage	$r_j$	$R_j$	$X_j$	$V_j$	$V_j \cdot X_j$
01	0.4697	0.8626	3.2	374	1197
02	0.4481	0.9205	4.3	512	2201
03	0.6000	0.9900	5.1	314	2602
Total volume					5000

Table 3: Volume constraint details  
System reliability =  $R_s = 0.7860$

6. HEURISTIC METHOD

Since the Lagrangian method gives a real valued solution, a heuristic approach is applied to derive an approximate integer solution.

6.1 Heuristic algorithm

- Step 1: Initialise and enter the values of required input parameters.
- Step 2: Enter the maximum number of components (n).
- Step 3: Initialise the number of components, set to 1 for the 1<sup>st</sup> stage, and calculate the values of system cost (C), weight (W), volume (V) for the 1<sup>st</sup> stage.
- Step 4: Initialise the number of components, set to 1 for the 2<sup>nd</sup> stage, and calculate the values of system cost(C), weight(W), volume(V) for the 2<sup>nd</sup> stage.
- Step 5: (i) Initialise the number of components, set to 1 for the 3<sup>rd</sup> stage, and calculate the values of system cost (C), weight (W), volume (V) for the 3<sup>rd</sup> stage.
  - (ii) Sum up all the values C, W, V for all three stages.
  - (iii) Calculate the system reliability ( $R_s$ ).
  - (iv) Check the constraints.
- Step 6: (i) If the constraints are satisfied, print the corresponding values of number of components and system reliability ( $R_s$ ).
- (ii) If the constraints are not satisfied, increment the number of components of stage three by 1 and go to Step 5.
- (iii) Repeat the above step until the number of components in all three stages reaches the value less than or equal to the maximum number of components (n).

i) Reliability design relating to cost

Stage	$r_j$	$R_j$	$x_j$	$c_j$	$c_j \cdot x_j$
01	0.4697	0.9209	4	374	1496
02	0.4481	0.9072	4	512	2048
03	0.6000	0.9360	3	314	942
Total cost					4486

Table 4: Reliability design relating to cost  
Variation in total cost = 10.28%

ii) Reliability design relating to weight

Stage	$r_j$	$R_j$	$X_j$	$W_j$	$W_j \cdot X_j$
01	0.4697	0.9209	4	548	2192
02	0.4481	0.9072	4	641	2564
03	0.6000	0.9360	3	576	1728
Total weight					6484

Table 5: Reliability design relating to weight  
Variation in total weight = 12.96%

iii) Reliability design relating to volume

Stage	$r_j$	$R_j$	$X_j$	$V_j$	$V_j \cdot X_j$
01	0.4697	0.9209	4	374	1496
02	0.4481	0.9072	4	512	2048
03	0.6000	0.9360	3	314	942
Total volume					4486

**Table 6: Reliability design relating to volume**  
 System reliability ( $R_s$ ) = 0.7820  
 Variation in total volume = 10.28%  
 Variation in system reliability = 0.51%

6.2 Sensitivity analysis

It is observed that when the input data of constraints is increased by 10%, there is only a 4.09% increase in system reliability. When the input data is decreased by 10%, there is only an 8.3% decrease in system reliability. When one factor is varied, keeping all the other factors unchanged, the variation in system reliability is as shown in Table 7.

Variation in factors		System reliability
Cost	10% decrease	No change
	10% increase	No change
Weight	10% decrease	No change
	10% increase	No change
Volume	10% decrease	8.37% decrease
	10% increase	4.09% increase

**Table 7: Sensitivity analysis**

The analysis confirms that the volume factor is more sensitive to input data than are cost and weight.

7. INTEGER PROGRAMMING

The heuristic approach commonly provides a workable solution which is approximate one. To validate the established redundant reliability system, the IP method is applied.

i) Reliability design relating to cost constraint

Stage	$r_j$	$R_j$	$X_j$	$C_j$	$C_j \cdot X_j$
01	0.4697	0.9209	4	374	1496
02	0.4481	0.9072	4	512	2048
03	0.6000	0.9360	3	314	942
Total cost					4486

**Table 8: Reliability design relating to cost**  
 Variation in total cost = 10.28%

ii) Reliability design relating to weight constraint

Stage	$r_j$	$R_j$	$X_j$	$W_j$	$W_j \cdot X_j$
01	0.4697	0.9209	4	548	2192
02	0.4481	0.9072	4	641	2564
03	0.6000	0.9360	3	576	1728
Total weight					6484

**Table 9: Reliability design relating to weight**  
 Variation in total weight = 12.97%

iii) *Reliability design relating to volume*

Stage	$r_j$	$R_j$	$X_j$	$V_j$	$V_j \cdot X_j$
01	0.4697	0.9209	4	374	1496
02	0.4481	0.9072	4	512	2048
03	0.6000	0.9360	3	314	942
Total volume					4486

**Table 10: Reliability design relating to volume**  
System reliability ( $R_s$ ) = 0.7820  
Variation in total Volume = 10.28%  
Variation in system reliability = 0.51%

## 8. CONCLUSIONS

This paper is focused on establishing a novel multiple constraint redundant reliability system, discussing the design and optimisation of the system in detail. The paper infers that the multiple constraints problem is first treated by the Lagrangian method, where this method provides a real valued solution, and as such may not be feasible for practical implementation. For this reason, the problem when treated heuristically proves to be a convenient and workable solution; and to present the exact solution, the proposed model is validated through the IP approach. The result of this work may not show any significant difference in deriving the solutions, but in many practical situations, the authors believe that the reported procedure is a scientific approach to deriving the solution for the series-parallel redundant reliability system with multiple constraints.

## 9. ACKNOWLEDGEMENT

V.S.S. Yadavalli is grateful to the National Research Foundation for its financial support.

## 10. REFERENCES

- [1] Balaguruswamy, E. 2002. Reliability engineering, Tata McGraw Hill, New Delhi.
- [2] Aggarwal, K.K. & Gupta, J.S. 1975. *On minimizing the cost of reliable systems*, IEEE Transactions on Reliability, Vol. R-24, No.3.
- [3] Mishra, K.B. 1972. *Reliability optimization of series-parallel system*, IEEE Transactions on Reliability, Vol. R-21, No.4.
- [4] Misra, K.B. 1971. *A method of solving redundancy optimization problems*, IEEE Transactions on Reliability, Vol. R-20, No. 3.
- [5] Fan, L.T. & Wang, T. 1997. *Optimization of system reliability*, IEEE Transactions on Reliability, Vol. R-16.
- [6] Aggarwal, K.K., Mishra, K.B. & Gupta, T.S. 1975. *Reliability evaluation: A comparative study of different techniques*, Microelectronics and Reliability, Vol.14, pp 49-56
- [7] Mettas, A. 2000. *Reliability allocation and optimization for complex systems*, Proceedings of Annual Reliability and Maintainability Symposium, Los Angeles, California, USA.
- [8] Ushakov, L.L. 2002: *Multi-state system reliability: From theory to practice*. Proceedings of 3<sup>rd</sup> International Conference on Mathematical Methods in Reliability, Trondheim, Norway, pp 635-638
- [9] Kuo, W. & Rajendra Prasad, V., 2000. *An annotated overview of system reliability optimization*, IEEE Transactions on Reliability, Vol. 49, No. 2, pp 176-187